

Microprocessor Cycle Counter

MLC - 02 / 03N version -02 D

User manual



The microprocessor MLC-02/03 counter is used to control the sharpening cycle of the automatic grinding machine for circular and band saw blades.

Mounting the counter panel.

Before mounting, cut a rectangular hole measuring 70 x 70 mm in the machine control panel. Possible unevenness of the edge post-cutting should be smoothed with a fine file and protected against corrosion with good quality paint or varnish. At each corner, an assembly hole should be made, with a diameter of 4.5 mm, in accordance with Fig.1.

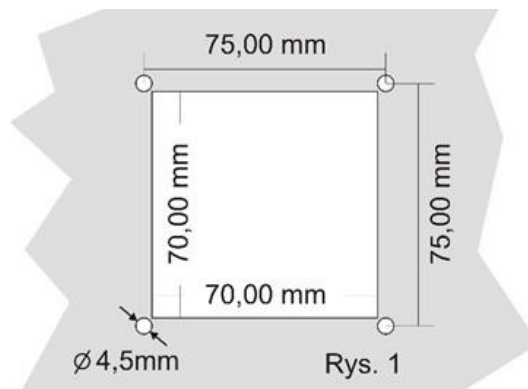

Fig. 1

After drilling the mounting holes, unscrew the four corner screws from the counter panel, remove the metal washers and plastic bushes and place the panel in the prepared place. Then, tighten the panel to the pulpit, using previously unscrewed screws, inserting the bush, the washer and finally tightening with the mounting screw.

Electrical installation of the counter



WARNING!

Due to the risk of electric shock, all connections should only be made when the power supply to the machine has been completely disconnected. It is best to turn off the main machine switch!!

Mounting of the TSS-4/002 supply transformer

The cable ends should be cleaned and fitted with sleeve ends or tinned before tightening. This is important for the correct and trouble-free operation of the counter in the future.

Install the transformer supplied in the set (**TSS-4/002**) in the machine's power cabinet.

The transformer mounting is designed for a typical TSS-35 mounting rail, commonly used in electrical machines. The spot for mounting the transformer should be chosen so that it is located as far away as possible from other electrical components (contactors, other transformers). This is important due to the possibility of electromagnetic interference penetration through the transformer into the counter's electronic system.

Connect the wires with which the voltage supplying the transformer (230V) will be fed to the transformer terminals marked as **PRI 230V**. The 230V power cables should be run as far as possible from the other wires in the cabinet.

The transformer terminals marked as **SEC 12V** should be connected with wires which will be used to power the electronic board of the MLC-02 / 03N counter. As in the case of the previous connection, they should be routed as far as possible from the other wires of the machine, including the 230V wires, which supply the transformer. The length of the power cord (12V) should be selected accordingly to the spot where the counter will be installed. Wires connected to **SEC 12V** terminals, after connecting to the counter, should be connected to connectors marked as **PWR** on the MLC-02 / 03N board.

Microswitch installation

The microswitch supplied in the set should be mounted in the grinder so that it will be switched on for a moment, after the sharpening tool passes through each subsequent tooth of the sharpened saw. The switch-on should take place after the sharpening of each tooth, that is, at the bottom of the tooth. The location of the microswitch should provide protection against contamination resulting from the sharpening process. Connect a pair of electric wires equipped with female terminals to the microswitch terminals marked as **COM** and **NO**; you can also solder the wires directly to the leads, taking care not to overheat these terminals during soldering.

After mounting and connecting the microswitch, the other two terminals, which, like the transformer, are provided with bushing or tinned terminals, are connected to the connectors on the counter board, marked as **PULSE**.

Connection of control outputs

Output **W-1** is normally shorted after switching on the power supply, it is used to turn off the grinder after the end of the sharpening cycle.

A pair of wires should be connected to the W-1 connector, similarly to the previously prepared ones, and the free ends connected **in series** with the contactor coil switching on the power supply of the grinder (Fig).

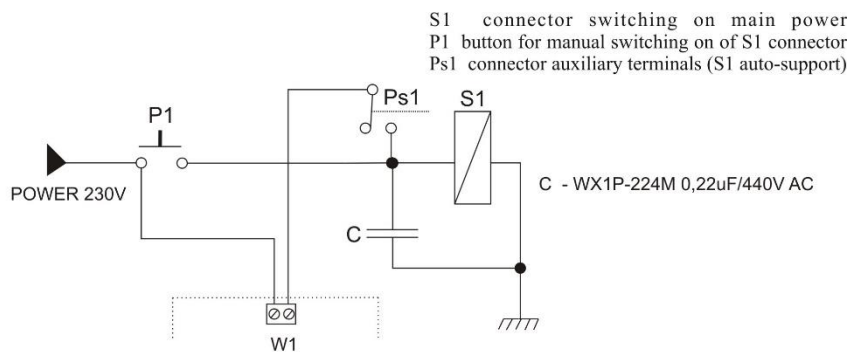

W1 terminal on the MLC-02/03N counter board
W1 is active (shorted) after switching on the counter power, until the end of the sharpening cycle.
After the sharpening cycle is finished, it is opened for 1s, in order to switch off the S1 connector

The grinder should be equipped with a main contactor to switch off the feed drive, blade and coolant pumps, and the control output should be connected to this contactor; this will ensure complete switching off of the grinder after the sharpening cycle finishes. It should be remembered in this case that the location of connecting the power supply of the counter itself should be selected so that it is powered all the time, regardless of the disconnected contactors!

It is absolutely necessary to connect the supplied WXP 224-R22 300V CPZ-type capacitors to contactor S-1, S2 and S3 coils, in accordance with the drawings.

Connecting the capacitors is very important for correct counter operation!

Operation of the MLC-02 / 03N counter

Operation of the device is limited to entering the number of teeth of the sharpened saw and the number of sharpening cycles to be performed. Using the "**DWN and UP**" buttons, set the number of teeth of the saw within the range **1 to 999**; holding the button causes accelerated addition or subtraction of the number, and using the "**CYCLE**" button sets the number of sharpening cycles within the range of **1 to 9**. After changing the number of teeth or cycles, the counter automatically saves the change to the memory after a while, which is confirmed by the caption "**INPUT SAVED**".

After the mechanical setting of saw sharpening parameters, press the "**START**" button.

"**START PROCESS**" appears on the display, the counter switches on the sharpening wheel drive and after approx. 7 seconds after switching on the wheel, the feed of the sharpened saw starts.

The counter starts working from this moment and stops the machine when it reaches the programmed number of sharpening operations.

The end of the cycle is signaled by "**END PROCESS**", this message is displayed until the "**START**" or "**RESET**" button is used again.

If for some reason during the operation, the counter power is switched off, after turning it on again, the counter displays the message "**POWER DEFAULT**" and after pressing the "**START**" button, it will return to counting the interrupted sharpening cycle from the moment where the power was turned off.

The "**RESET**" button restores the last number of teeth and cycles recorded.

If, during the counting, a microswitch fault occurs, a break in its circuit or other cause resulting in absence of counting pulses on the "**PULSE**" input, the counter will stop the counting cycle after about 15 seconds and display the message "**IMPULSES DEFAULT**". After removing the malfunction, the counter may be brought back to operation by pressing the "**RESET**" button.

Operating recommendations

Do not use hard objects to press the keyboard of the controller, it may cause irreversible damage.

If the keyboard gets dirty, use popular cleaning agents for cleaning, remembering not to press the membrane keys too hard. Pressing the keys too hard may cause damage and necessity to replace the entire keyboard.

The adjuster should not be exposed to direct wetting, inundation with water or other liquids.

EMC compliance

The MLC-02 / 03N counter corresponds to the standards regarding electromagnetic compatibility (EMC) in this respect.

The MLC_02 / 03N counter should be installed and configured in accordance with European and national standards. The installers of the machine's electrical control system, required to comply with the EMC directive, are responsible for adapting the device.

The MLC-02 / 03N counter must be considered as a component, it is not a machine or device ready for use, according to European directives (machine directive and electromagnetic compatibility directive). The end user installing the MLC-02 / 03N counter in a machine is responsible for meeting these standards.

The product and equipment described in this documentation can be changed and modified many times, both from a technical point of view and the way it is operated.

Their description cannot be treated as a contract in any way.